

SECTION D-D ( 1 : 20 )

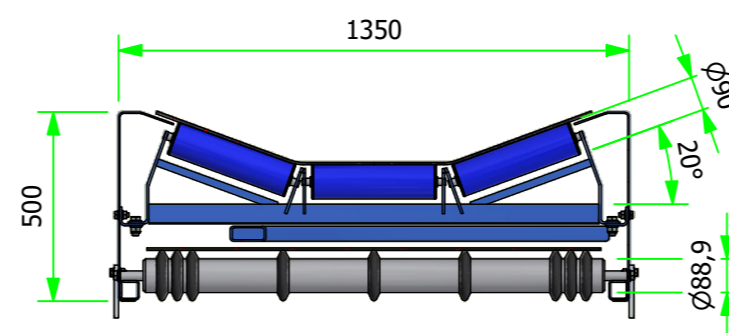

SECTION C-C ( 1 : 20 )

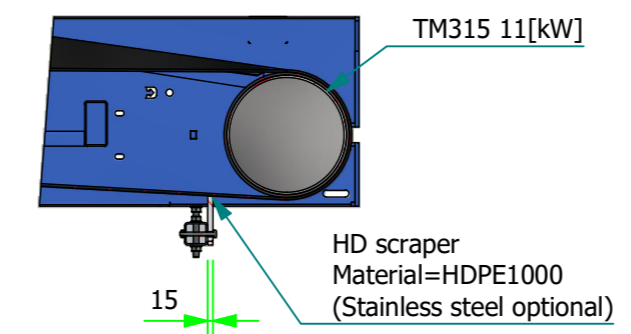

**Specifications**

- Low position**
  - Mass Capacity 1000[ton/hr] (Calculated with wet sand)
  - Volume Capacity 640[m<sup>3</sup>/hr] (Product specific, calculated with wet sand)
- High position**
  - Mass Capacity 425[ton/hr] (Calculated with wet sand)
  - Volume Capacity 270[m<sup>3</sup>/hr] (Product specific, calculated with wet sand)
- Drummotor power 11[kW] (Y-Δ Circuit)
- Electric box Steel (coated)
- Conveyor length 13.0[m]
- Conveyor width 1,2[m]
- Belt speed 2,0[m/s]
- Belt type 250/2 3+1,5 (400/3 4+2 Optional)
- Rollers 20° V-shape carrier rollers (Plastic, Steel rollers optional)

		<b>VAN TRIER</b>	
		Opmerking: EB 13-120 BL-H	
Get.:	1 : 50   A2	Ordernummer:	Opdrachtgever:
Datum:			Tekeningnummer:
22 0803-300.idw			Rev.:
		sheet 1/1	