

- *Overall options***
- Line control
 - Switched power outlet
 - Led trailer detection
 - Double rubber side flaps
 - Dosing slider
 - Custom options

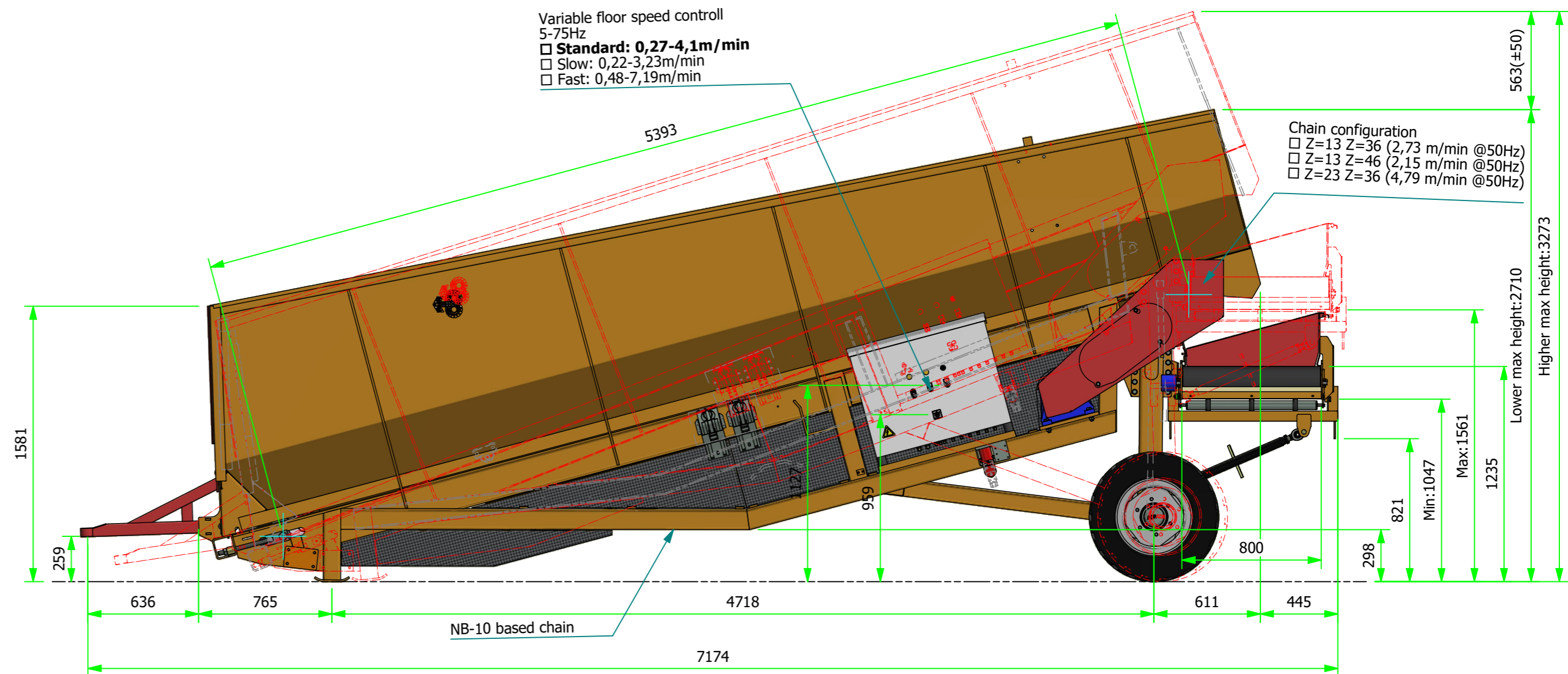
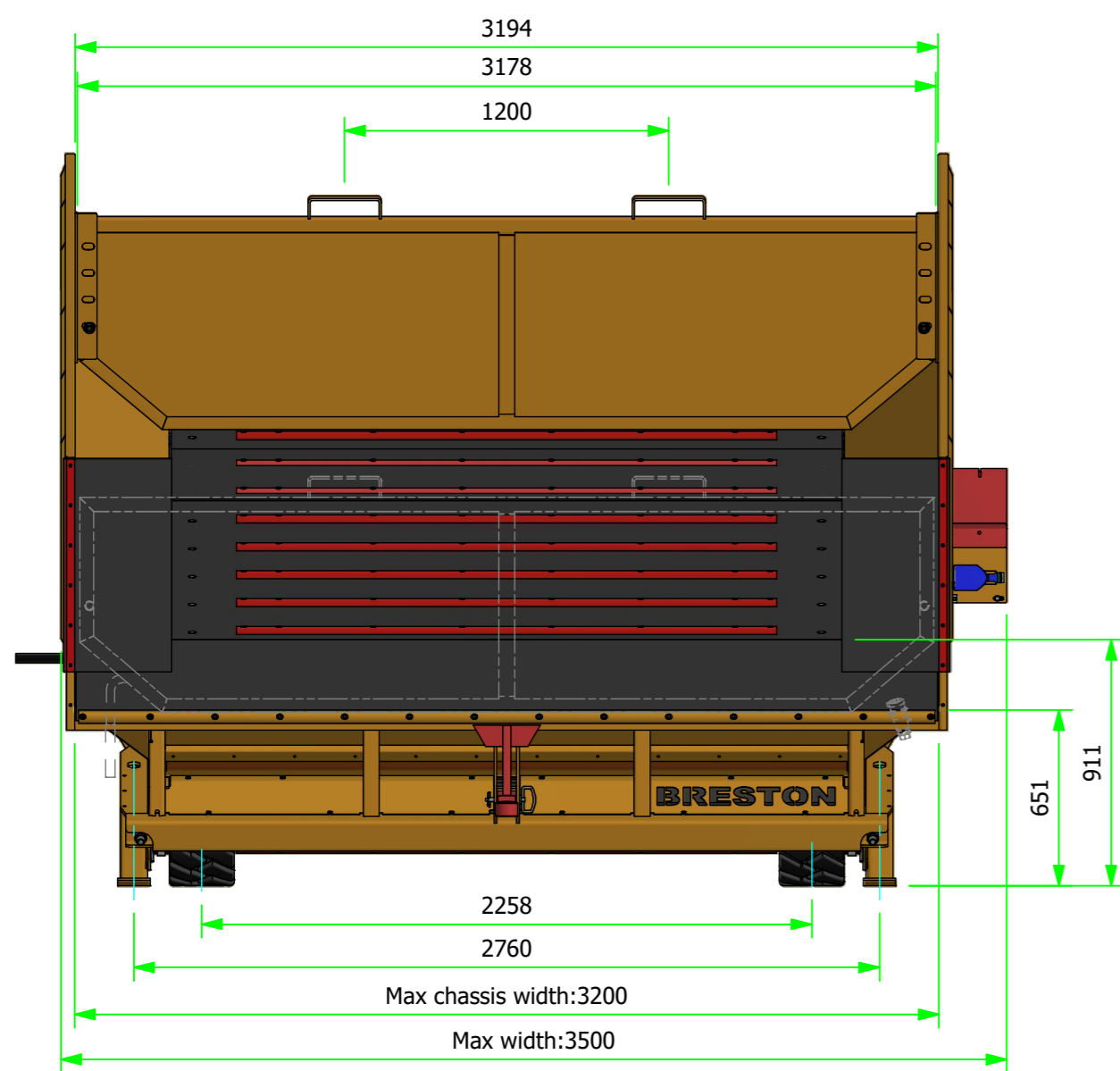
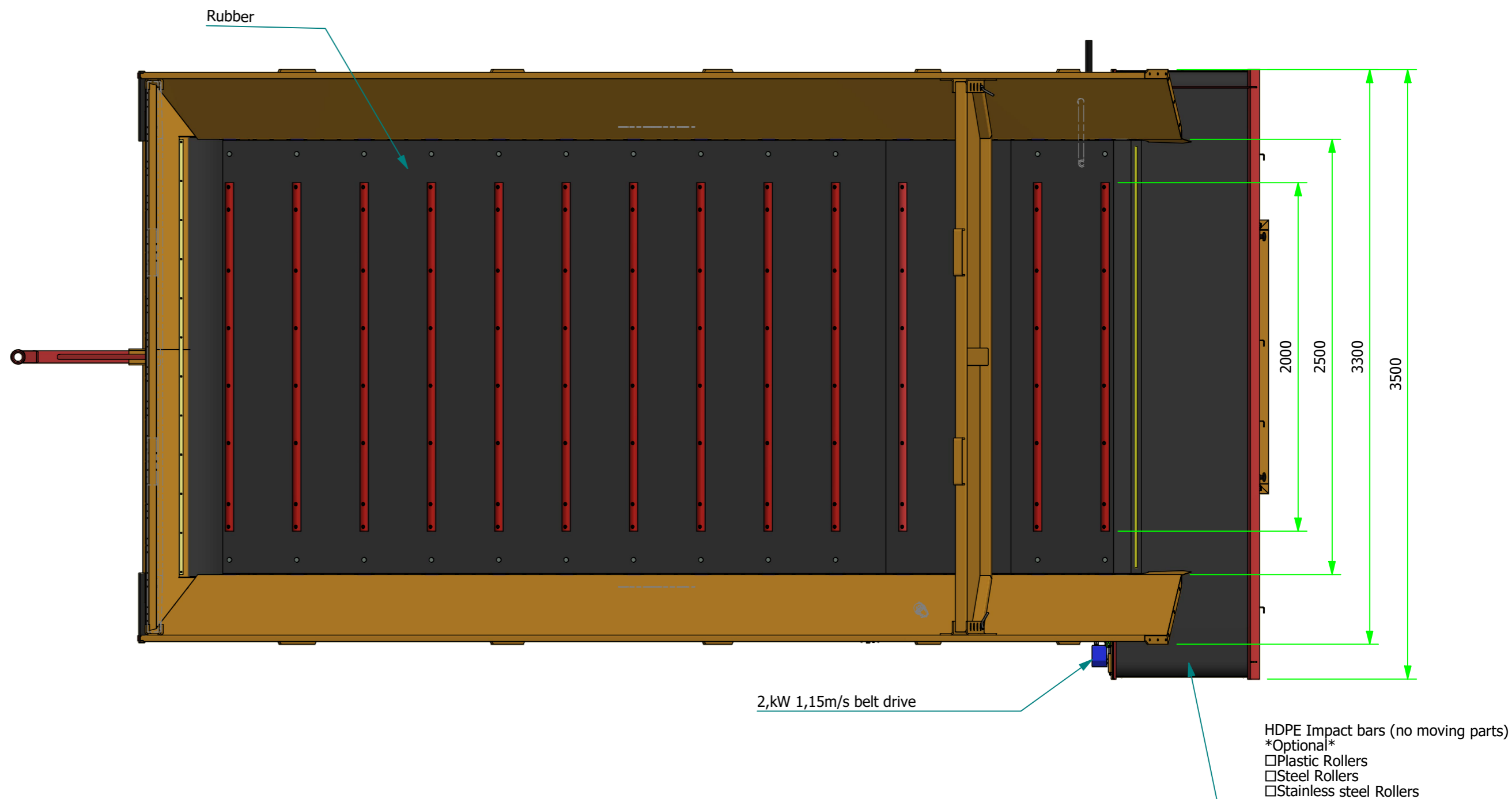
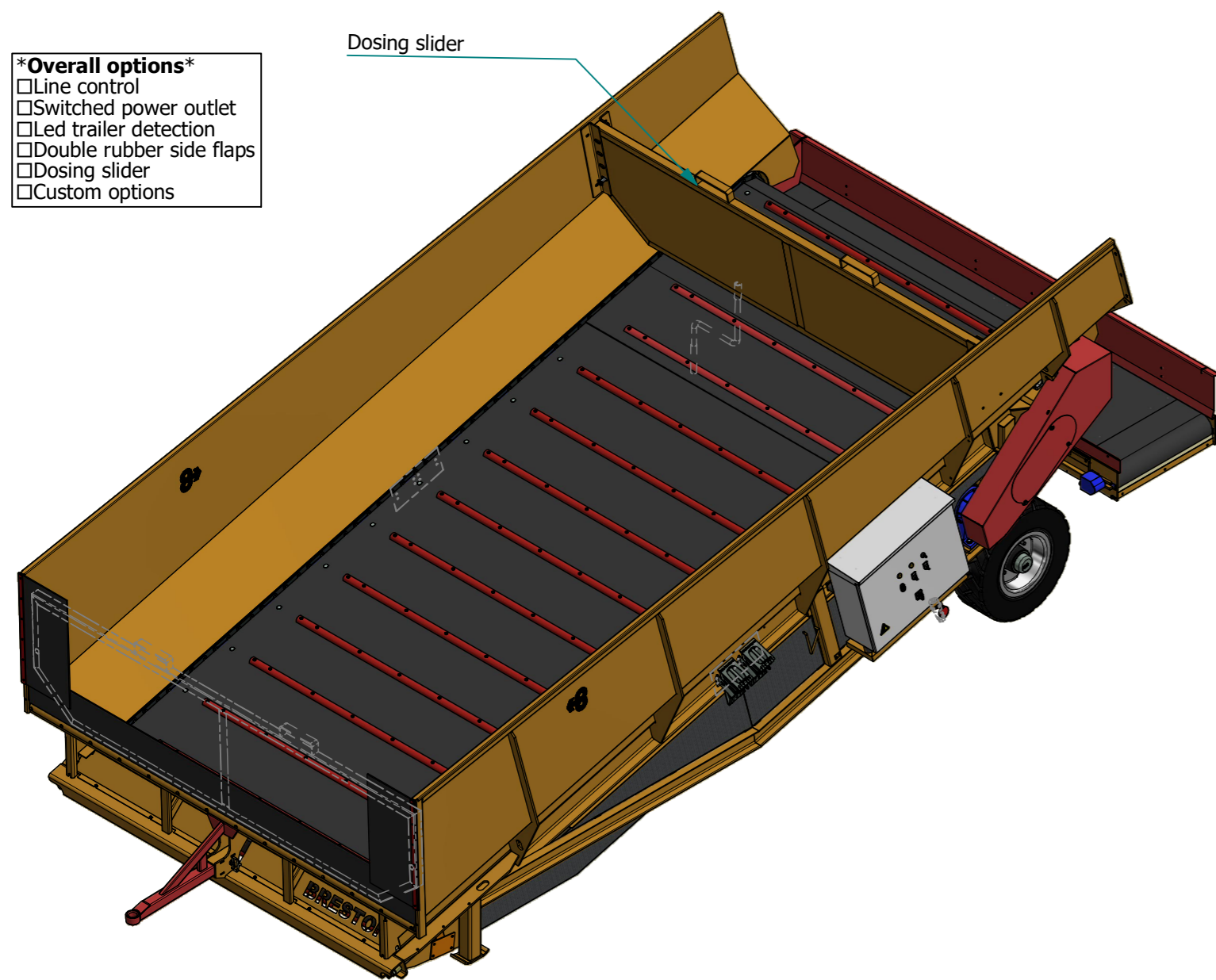

NB10-250B					
Opmerking:					
Ontwerp:	Aangepast:	1 : 25 A2	Ordernummer:	Oprachtgever:	Tekeningnummer:
Datum:	Laatst aangep.:				Rev.:
		N/A			