

- *Overall options***
- Line control
 - Switched power outlet
 - Led trailer detection
 - Double rubber side flaps
 - Dosing slider
 - Custom options

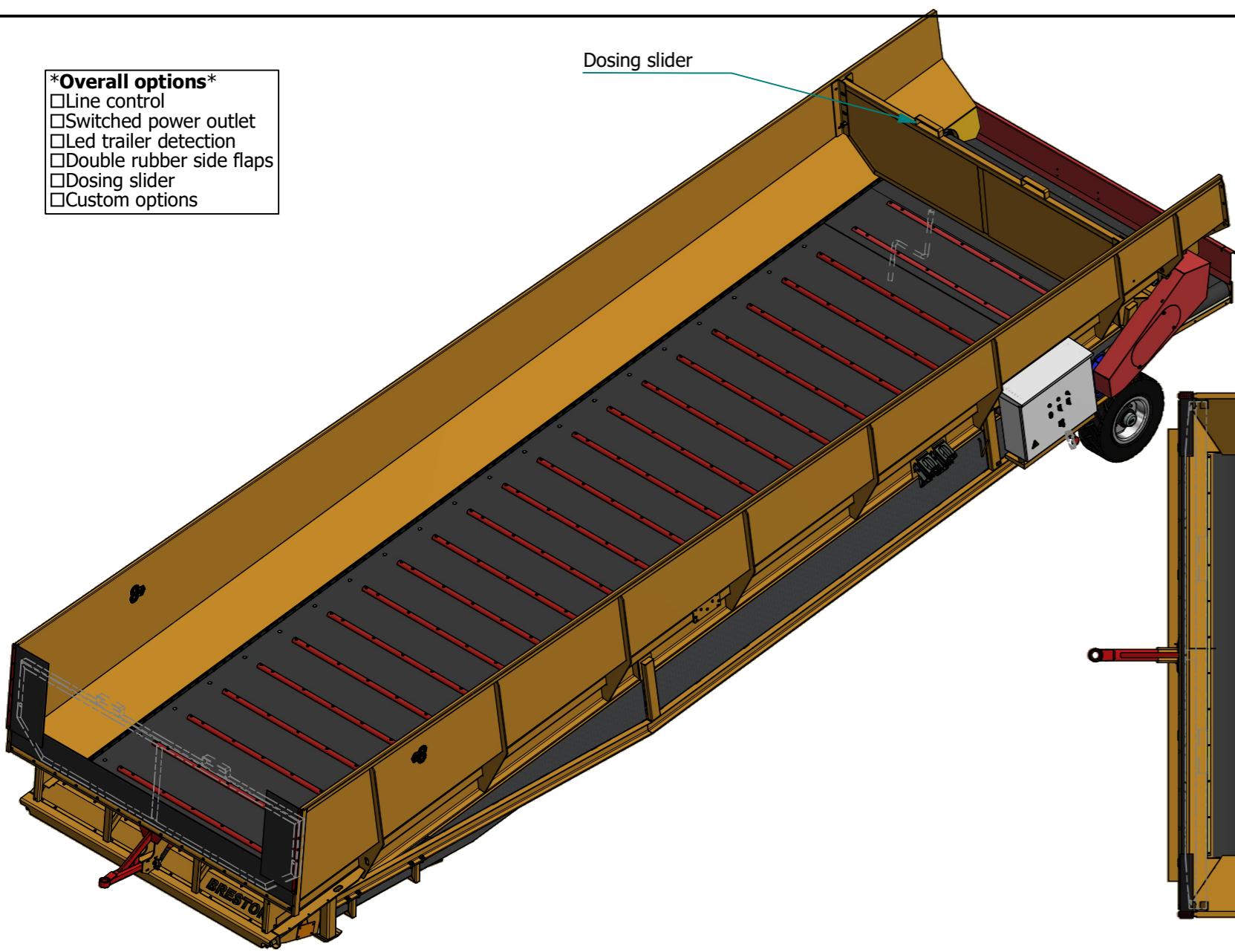

Dosing slider

- HDPE Impact bars (no moving parts)
- *Optional***
- Plastic Rollers
 - Steel Rollers
 - Stainless steel Rollers

Rubber

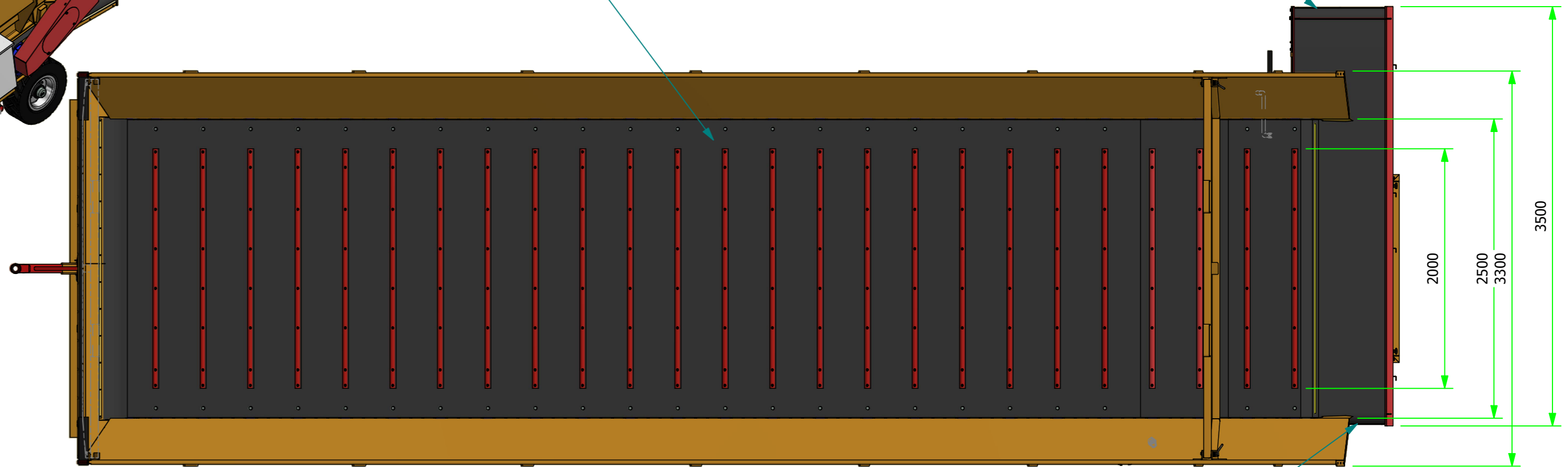

2.2kW 1.1m/s belt drive

2000
2500
3300
3500

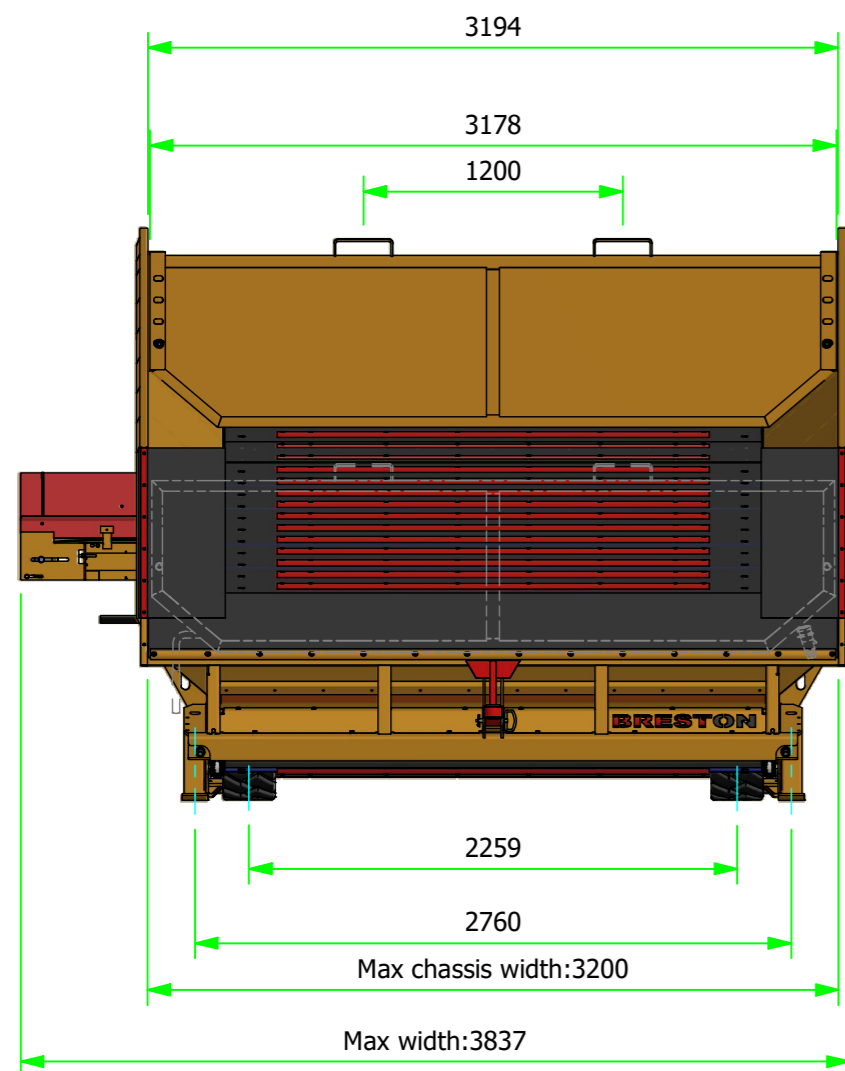

3194

3178

1200

2259

2760

Max chassis width:3200

Max width:3837

- Variable floor speed controll
5-75Hz
- Standard: 0,27-4,1m/min**
 - Slow: 0,22-3,23m/min
 - Fast: 0,48-7,19m/min

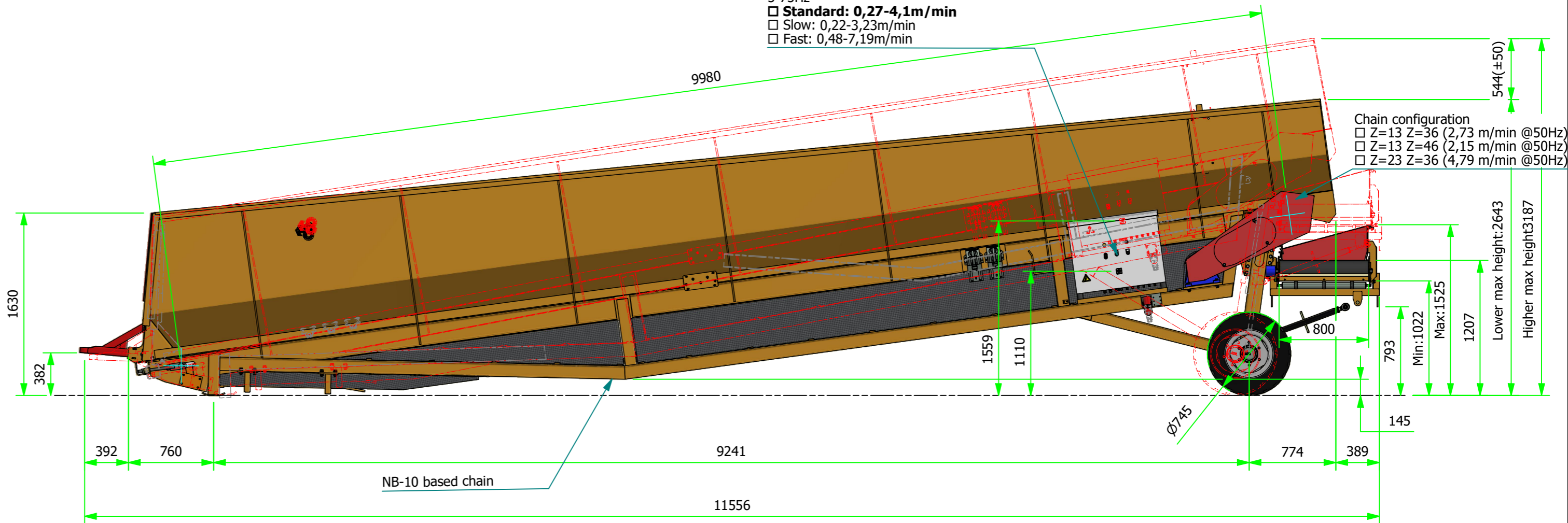

9980

1630

382

392

760

9241

11556

NB-10 based chain

1559

1110

Ø745

800

774

389

145

793

Min:1022

Max:1525

1207

Lower max height:2643

Higher max height:3187

544(±50)

- Chain configuration
- Z=13 Z=36 (2,73 m/min @50Hz)
 - Z=13 Z=46 (2,15 m/min @50Hz)
 - Z=23 Z=36 (4,79 m/min @50Hz)

NB10-250K



Ontwerp:		Aangepast:		1 : 35	A2	Ordernummer:	Opdrachtgever:		Tekeningnummer:	Rev.:
Datum:		Laatst aangep.:								sheet 1/1